

Available online at: <http://ajceet.ft.unand.ac.id/>

## Andalas Journal of Electrical and Electronic Engineering Technology

ISSN 2777-0079

**AJCEET**  
 Andalus Journal of Electrical and Electronic Engineering Technology

Electrical Power and Energy

# Load Flow Analysis and Short Circuit Faults with the Additional Distributed Generation Wind Turbine 300 Kw at Andalas University

*Fadhel Putra Winarta<sup>1</sup>, Yoli Andi Rozzi<sup>1</sup>*
<sup>1</sup> Master Program in Electrical Engineering, Faculty of Engineering, Andalas University, West Sumatra

### ARTICLE INFORMATION

Received: April 24, 2021  
 Revised: May 3, 2021  
 Accepted: May 5, 2021

### KEYWORDS

Power Flow Analysis, Short Circuit Analysis, Distributed Generation, Wind Turbine

### CORRESPONDENCE

Phone: +62-82372006154  
 E-mail: fadhelwinarta@gmail.com

### A B S T R A C T

The study of electric power flow analysis (Load Flow) is intended to obtain information about the flow of power or voltage in an electric power system network. This information is needed to evaluate the performance of the power system. Electrical power flow problems include calculating the flow and system voltage at certain terminals or buses. The benefits of this power flow study are to find out the voltage at each node in the system, to find out whether all the equipment meets the specified limits to deliver the desired power, and to obtain the original conditions in the new system planning. This study is divided into two: the analysis of data when the conditions have not been added wind turbine and after the addition of 300 kW wind and the Newton-Raphson method will be used in analyzing the power flow of the electric power system. Based on the results of the tests, it is found that the overall value of losses for power flow before the addition of DG is 0.031 MW and 0.037 Mvar, for the voltage drop with the lowest percentage, namely on bus 10 with a percentage of 96.45 for the 0.4 kV system and the 20 kV system on bus 19 with a percentage of 99.03, the largest% PF load was in lump 1 with 98.64 and the smallest% PF was in lump7 with a value of 84.92. The short circuit data value on the 20 kV bus system at Andalas University before the addition of DG with 3-phase disturbances averaged 13.354 A, 1-phase disturbances averaged 3.521 A, 2-phase disturbances averaged 11.719 A and 2 ground phases of 12.842 A Whereas for the value of power flow after the addition of DG in the form of the wind turbine of 300 kW the overall value of losses is 0.032 MW and 0.042 MvarAR, for the voltage drop with the percentage for voltage drop with the lowest percentage is bus 10 with a percentage of 96.63 for system 0, 4 kV and a 20 kV system on bus 14 with a percentage of 98.1, the largest% PF load is in lump 1 with 98.64 and the smallest% PF is in lump7 with a value of 84.92. The short circuit data value on the 20 kV bus system at Andalas University after the addition of DG with 3 phase disturbances has an average value of 13.354 A, 1 phase disturbance averages 3.523 A, 2 phase disturbances average 11.737 A and 2 phases ground is 12.059 A For the source in this system, after the addition of DG, there was a change in the% PF of the PLN grid, namely 79.53 and the wind turbine -83%.

## INTRODUCTION

Analysis of the flow of electric power (Load Flow) is an analysis used to plan and determine the amount of power in an electric power system. During its development, the industry requires large electric power and uses electrical equipment as a means of production [1]. The benefit of the analysis of electric power flow is to determine the amount of power in the electric power system so that it can be seen whether it still meets predetermined limits, can find out the number of Losses that occurred, and to obtain initial conditions in the new system planning. This analysis includes determining the amount of voltage (V), active power (P), reactive power (Q), and phase angle ( $\delta$ ) of each bus in the system [2]. Furthermore, the main objective of the power system study is to determine the voltage magnitude, voltage angle/vector, active

power flow and reactive power in the line, and power losses that appear in an electric power system.

Distributed Generations or often referred to as (DG) are small-scale power plants that are connected to the power grid and as a source of energy [3]. Distributed Generation (DG) is one of the technologies used for the latest generation of electrical systems so that consumers can connect directly to the power grid [4]. The benefits of DG have been evaluated in saving energy costs, energy value, and in terms of capacity as well as improving the voltage profile, reducing line losses and reducing environmental impact [3].

Wind Turbines have been developed in many countries, especially those that have a large wind power potential [5]. The exploitation of wind energy is expected to reduce dependence on power plants that use energy derived from oil or fossil fuels.

Electrical energy is generated by utilizing wind power through a turbine to drive an electric power generator. As wind energy is the most popular renewable energy source, the increased use of wind power in distribution systems can greatly affect the system's voltage stability during transients and sudden load changes [5].

ETAP is a comprehensive analysis software to design and simulate a power circuit system [2]. Analyzes that can be used by ETAP include load flow, short circuit, transient stability, etc. [6]. To analyze a series, complete and accurate series data is needed so that the calculation results can be justified.

This study aims to determine the electrical system at Andalas University with two conditions, namely when before the addition of the Wind Turbine and after the addition of the Wind Turbine of 300 kW at the feeder section Pauh Limo. The methods to be used are Newton-Raphson and ETAP as the software used to carry out the power flow mechanism regarding the performance of active power, reactive power, voltage profile, and power losses of each bus in the system. Then input will be given to optimizing the conditions in the electrical system after the power flow analysis mechanism is carried out.

## METHOD

This research will be carried out in several stages as follows:

1. Electric power system modeling using ETAP software
2. Data input process, namely: generator data, transformers, transmission lines, and loads.
3. Calculating the flow of power using the Newton-Raphson method
4. Evaluate the power flow and bus voltage on each bus in the system.

This study uses simulation software to analyze the flow of electric power. The data analysis process was carried out using the power flow calculation method. The data that has been obtained will then be analyzed, so that accurate data analysis results will be obtained and following existing theories.

Analysis of the flow of electric power with simulation software based on a single line diagram and input data from known research results. In running the software, the first step is to draw a line diagram of the electrical system at Andalas University. After the inline diagram is drawn, each component in the inline diagram such as the source (power grid), buses, loads, and others will be given input data according to the characteristics of these components. If the data entered is not correct, the simulation software will not run the command to analyze the power flow (error). Then after the data entered is complete and correct, then

the available power flow method will be selected. The Newton-Raphson method will be chosen to be used in running the program. Based on data analysis, the results can be used as an electrical reference at Andalas University. The results are in the form of a report consisting of input data and a report on the results of the power flow calculations performed by the program.

## RESULTS AND DISCUSSION

### *Transformer Capacity and Load Data*

In the distribution system at Andalas University, there are 9 transformers and 9 loads connected to the PLN GI Pauh Limo grid. The capacity value of the transformer in each area can be seen in Table 1.

Table 1. Transformer Capacity

Transformer Name	Capacity (kV)
Public Health	315
Engineering	630
Animal Sci	630
ISIP	630
Agriculture	1000
MIPA	1000
PKM	250
Hospital	2000
Medical	630

Furthermore, the load to be used is Lumped Load, with the load capacity value can be seen in Table 2.

Table 2. Load Capacity

No Bus	Load Name	kW	kVar
10	Public Health	199	123
8	Engineering	118	73.223
14	Animal Sci	156	96.401
12	ISIP	139	86.392
18	Agriculture	233	144
20	MIPA	268	166
16	PKM	133	82.705
4	Hospital	300	50
6	Medical	260	974.426
	Total	1806	974.426

### *Load Flow Study Data*

The load flow power flow simulation is applied to the electric power system at Andalas University. The simulation results of the single line diagram of the electric power system at Andalas University can be seen in Figure 1.

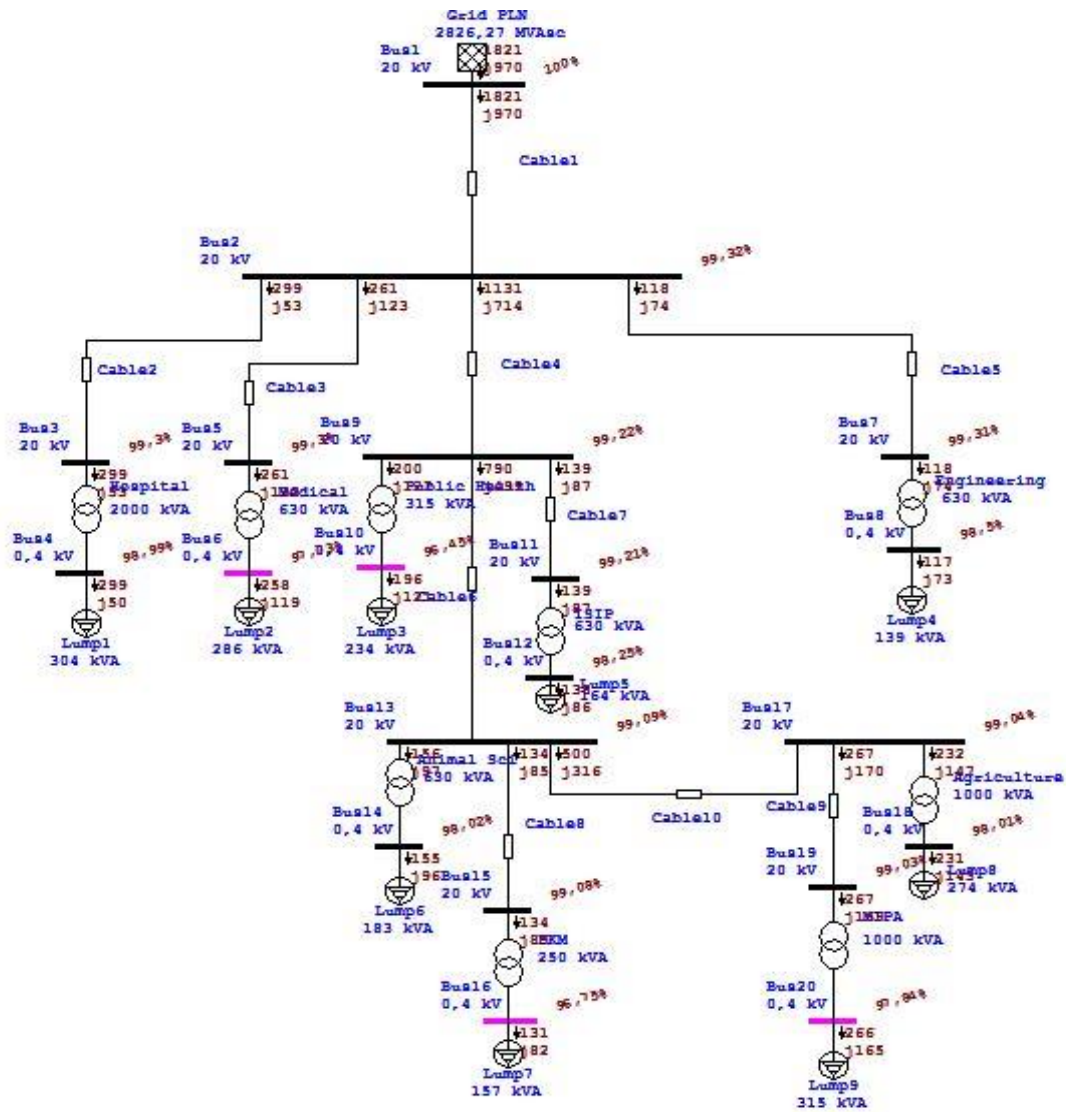

Figure 1. Single Line Diagram of Andalas University Electric Power System

Table 3. Overall Load Flow Data

Study ID	Untitled
Study Case ID	LF
Data Revision	Base
Configuration	Normal
Loading Cat	Design
Generation Cat	Design
Diversity Factor	Normal Loading
Buses	20
Branches	19
Generators	0
Power Grids	1
Loads	9
Load-MW	1,821
Load-Mvar	0,97
Generation-MW	1,821
Generation-Mvar	0,97
Loss-MW	0,031
Loss-Mvar	0,037
Mismatch-MW	0
Mismatch-Mvar	0

Table 3 shows the power losses that occur in the electric power system at Andalas University as a whole. This system has active power losses of 0.031 MW and reactive power losses of 0.037 Mvar

Table 4. Bus Drop Data

ID Bus	Nominal kV	Voltage	MW Loading
Bus 1	20	100	1,821
Bus 2	20	99,32	1,809
Bus 3	20	99,3	0,299
Bus 4	0,4	98,99	0,299
Bus 5	20	99,3	0,261
Bus 6	0,4	97,73	0,258
Bus 7	20	99,31	0,118
Bus 8	0,4	98,5	0,117
Bus 9	20	99,22	1,13
Bus 10	0,4	96,45	0,196
Bus 11	20	99,21	0,139
Bus 12	0,4	98,25	0,138
Bus 13	20	99,09	0,789
Bus 14	0,4	98,02	0,155

Bus 15	20	99,08	0,134
Bus 16	0,4	96,75	0,131
Bus 17	20	99,04	0,499
Bus 18	0,4	98,01	0,231
Bus 19	20	99,03	0,267
Bus 20	0,4	97,84	0,266

In table 4, the purple voltage column indicates the bus is in Marginal condition (safe critical condition) while the colorless one is still within safe limits. The lowest bus voltage obtained in the Load Flow simulation using ETAP, for a 0.4 kV system the largest voltage drop occurs on bus 10 with a percentage of 96.45%. Meanwhile, for a 20 kV system, the largest voltage drop occurred on bus 19 with a percentage of 99.03%.

Table 5. Branching Load Flow Data

ID	Type	kW Flow	kvar Flow	Amp Flow
Cable1	Cable	1821	970	59,58
Cable2	Cable	299	52,712	8,834
Cable3	Cable	261	123	8,383
Cable4	Cable	1131	714	38,88
Cable5	Cable	118	73,833	4,046
Cable6	Cable	790	499	27,2
Cable7	Cable	139	87,246	4,775
Cable8	Cable	134	85,055	4,613
Cable9	Cable	267	170	9,222
Cable10	Cable	500	316	17,23
T2	Transf. 2W	299	52,685	8,834
T3	Transf. 2W	261	123	8,383
T4	Transf. 2W	118	73,824	4,046
T5	Transf. 2W	200	127	6,904
T6	Transf. 2W	139	87,238	4,775
T7	Transf. 2W	156	97,466	5,358
T8	Transf. 2W	134	85,047	4,613
T9	Transf. 2W	232	147	8,004
T10	Transf. 2W	267	169	9,222

Table 6. Data Load Flow Report (Load)

ID	kW	Amp	% PF
Lump1	299	441,7	98,64
Lump2	258	419,1	90,8
Lump3	196	345,2	85,06
Lump4	117	202,3	84,97
Lump5	138	238,8	84,93
Lump6	155	267,9	85,07
Lump7	131	230,7	84,92
Lump8	231	400,2	85,07
Lump9	266	461,1	85,01

The simulation results of % PF are shown in table 6 with the largest% PF in Lump1 while the lowest% PF in Lump7.

Table 7. Source

ID	Rating	Rated kV	MW	Mvar	Amp	% PF
Grid PLN	2826,27 MVA	20	1,821	0,97	59,58	88,26

**Short Circuit Data on a 20 kV Bus System**

Table 8. Short Circuit Analysis Data on 20 kV Bus

Bus ID	3-Phase Fault	Line-to-Ground Fault	Line-to-Line Fault	Line-to-Line-to-Ground
Bus1	81,587	7,392	70,893	72,153
Bus2	9,042	3,808	8,037	8,271
Bus3	7,623	3,467	6,757	6,996
Bus5	7,623	3,467	6,757	6,995
Bus7	7,067	3,317	6,253	6,492
Bus9	7,390	3,410	6,581	6,815
Bus11	6,413	3,133	5,694	5,928
Bus13	5,664	2,903	5,048	5,273
Bus15	5,071	2,700	4,510	4,730
Bus17	4,819	2,611	4,293	4,508
Bus19	4,590	2,525	4,087	4,299

**Load Flow Study Data with the Addition of Wind Turbine 300 kW**

The load flow power flow simulation is applied to the electric power system at Andalas University. The simulation results of the single line diagram of the electric power system at Andalas University with the addition of a Wind Turbine of 300 kW on the bus with the lowest voltage magnitude from the results of the previous load flow data analysis, namely on bus 10 can be seen in Figure 2.

Table 9 shows the power losses that occur in the electric power system at Andalas University as a whole after adding the 300 kW Wind Turbine. This system has active power losses of 0.032 MW and reactive power losses of 0.042 Mvar

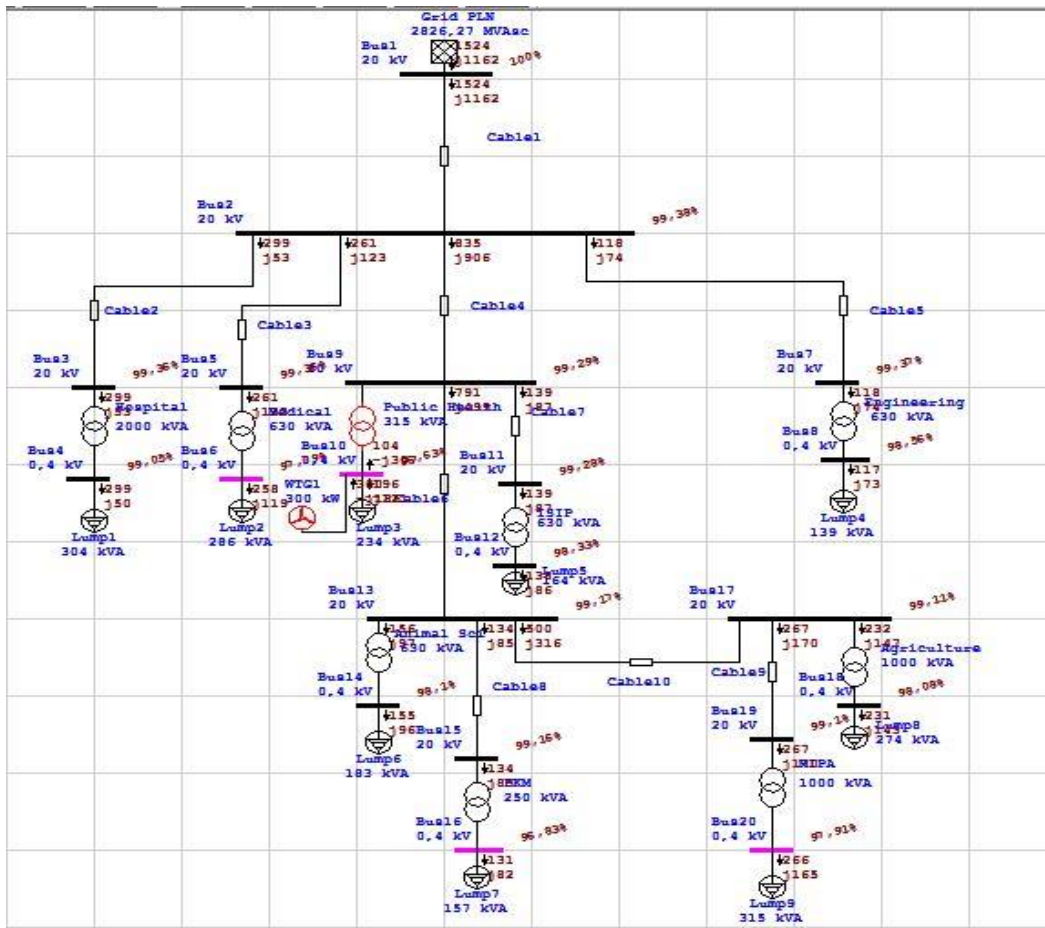

Figure 2. Single line diagram of Andalas University electric power system with Wind Turbine 300 kW.

Table 9. Overall load flow data

Study ID	Untitled
Study Case ID	LF
Data Revision	Base
Configuration	Normal
Loading Cat	Design
Generation Cat	Design
Diversity Factor	Normal Loading
Buses	20
Branches	19
Generators	0
Power Grids	1
Loads	9
Load-MW	1,824
Load-Mvar	0,976
Generation-MW	1,824
Generation-Mvar	0,976
Loss-MW	0,032
Loss-Mvar	0,042
Mismatch-MW	0
Mismatch-Mvar	0

10 with a percentage of 96.63. Whereas for a 20 kV system, the largest voltage drop occurred on bus 14 with a percentage of 98.1.

Table 10. Bus Drop Data

Bus ID	Nominal kV	Voltage	MW Loading
Bus1	20	100	1,524
Bus2	20	99,38	1,513
Bus3	20	99,36	0,299
Bus4	0,4	99,05	0,299
Bus5	20	99,36	0,261
Bus6	0,4	97,79	0,258
Bus7	20	99,37	0,118
Bus8	0,4	98,56	0,117
Bus9	20	99,29	0,93
Bus10	0,4	96,63	0,3
Bus11	20	99,28	0,139
Bus12	0,4	98,33	0,138
Bus13	20	99,17	0,789
Bus14	0,4	98,1	0,155
Bus15	20	99,16	0,134
Bus16	0,4	96,83	0,131
Bus17	20	99,11	0,5
Bus18	0,4	98,08	0,231
Bus19	20	99,1	0,267
Bus20	0,4	97,91	0,266

In table 10, the purple voltage column indicates the bus is in marginal condition (safe critical condition) while the colorless one is still within safe limits. The lowest bus voltage obtained in the load flow simulation after adding the Wind Turbine using ETAP, for a 0.4 kV system the largest voltage drop occurs on bus

Table 11. Balancing Load Flow Data

ID	Type	kW Flow	kvar Flow	Amp Flow
Agriculture	Transf. 2W	232	147	8
Animal Sci	Transf. 2W	156	97,493	5,356
Cable1	Cable	1524	1162	55,32
Cable2	Cable	299	52,722	8,83
Cable3	Cable	261	123	8,379
Cable4	Cable	835	906	35,8
Cable5	Cable	118	73,85	4,044
Cable6	Cable	791	499	27,18
Cable7	Cable	139	87,27	4,773
Cable8	Cable	134	85,076	4,611
Cable9	Cable	267	170	9,217
Cable10	Cable	500	316	17,22
Engineering	Transf. 2W	118	73,841	4,044
Hospital	Transf. 2W	299	52,695	8,83
ISIP	Transf. 2W	139	87,262	4,773
Medical	Transf. 2W	261	123	8,379
MIPA	Transf. 2W	267	170	9,217
PKM	Transf. 2W	134	85,069	4,611
Public Health	Transf. 2W	95,703	-319	9,688

Table 12. Data Load Flow Report (Load)

ID	kW	Amp	% PF
Lump1	299	441,5	98,64
Lump2	258	419	90,8
Lump3	196	344,8	85,06
Lump4	117	202,2	84,97
Lump5	138	238,6	84,93
Lump6	155	267,8	85,07
Lump7	131	230,5	84,92
Lump8	231	400	85,07
Lump9	266	460,9	85,01

The simulation results of % PF after being added with a wind turbine of 30 kW are shown in table 11 with the largest% PF in Lump1 while the lowest% PF is in Lump7.

Table 13. Source

ID	Rating	Rated kV	MW	Mvar	Amp	% PF
Grid PLN	2826,27 MVA	20	1,524	1,162	55,32	79,53
WTG1	0,3 MW	0,4	0,3	-0,186	527,2	-85

**Short Circuit Data on a 20 kV System with a Wind Turbine of 300 kW**

Table 14. Short Circuit Analysis Data on 20 kV Bus after adding 300 kW Wind Turbine

Bus ID	3-Phase Fault	Line-to-Ground Fault	Line-to-Line Fault	Line-to-Line-to-Ground
Bus1	81,587	7,392	70,924	72,185
Bus2	9,042	3,811	8,063	8,294

Bus3	7,623	3,469	6,776	7,012
Bus5	7,623	3,469	6,775	7,012
Bus7	7,067	3,319	6,269	6,506
Bus9	7,390	3,414	6,606	6,838
Bus11	6,413	3,136	5,714	5,945
Bus13	5,664	2,906	5,063	5,287
Bus15	5,071	2,702	4,522	4,741
Bus17	4,819	2,613	4,304	4,518
Bus19	4,590	2,527	4,097	4,308

**CONCLUSIONS**

This study discusses two scenarios that were analyzed and simulated. In the first condition, the power flow and short circuit will be analyzed in a 20 kV bus system without DG, while the second condition is after the addition of DG in the form of a Wind Turbine of 300 kW. From the analysis of the data obtained, it can be concluded that the overall Losses value for the power flow before the addition of DG is 0.031 MW and 0.037 Mvar. The voltage drop value with the lowest percentage occurs on bus 10 with a percentage of 96.45 for a 0.4 kV system, while for a 20 kV system occurs on bus 19 with a percentage of 99.03. Then for the largest% PF load in lump 1 with a value of 98.64% and the smallest% PF occurred in lump 7 with a value of 84.92%. Furthermore, it can be obtained the short circuit data value on the 20 kV bus system at Andalas University before the addition of DG with 3 phase disturbances with the acquisition of an average value of 13.354 A, 1 phase disturbance averaging 3.521 A, 2 phase disturbance averaging 11.719 A, and 2 phases to the ground amounted to 12,842 A. As for the value of the power flow after the addition of DG in the form of a Wind Turbine of 300 Kw. Losses values that occur as a whole are 0.032 MW and 0.042 Mvar, for the voltage drop with the lowest percentage, namely on bus 10 with a value of 96.63% on a 0.4 Kv system, and for a 20 kV system that occurs on bus 14 a percentage of 98 is obtained. , 1. For the largest% PF load was found in lump 1 with a value of 98.64 and the smallest% PF occurred in lump 7 with a value of 84.92. Then for the short circuit data value that occurs in the 20 kV bus system at Andalas University after the addition of DG with 3 phase disturbances, the average value is 13.354 A, 1 phase disturbance averages 3.523 A 2 phase disturbances average 11.737 A, and 2 ground phase is 12,059 A. Furthermore, the source value in this system is obtained, after the addition of DG, there is a change in the% PF of the PLN grid, namely 79.53 and the wind turbine -83%.

**ACKNOWLEDGMENT**

**REFERENCES**

[1] A. Zeggai and F. Benhamida, "Power flow and Short circuit of 220 kV Substation using ETAP," *Proc. Alger. Large Electr. Netw. Conf. CAGRE 2019*, pp. 158–163, 2019.

[2] N. Raphson, "Analisa Aliran Daya Sistem Tenaga Listrik Pada Bagian Penyulang 05Ee0101a Di Area Utilities Ii Pt . Pertamina ( Persero ) Refinery Unit Ivcilacap Menggunakan Metode," vol. 1, no. 1, pp. 1–6,

- 2019.
- [3] A. K. Singh and S. K. Parida, "Novel sensitivity factors for DG placement based on loss reduction and voltage improvement," *Int. J. Electr. Power Energy Syst.*, vol. 74, pp. 453–456, 2016.
- [4] A. M. Borbely and J. F. Kreider, "Distributed generation: The power paradigm for the new millennium," *Distrib. Gener. Power Paradigm. New Millenn.*, no. January 2001, pp. 1–400, 2001.
- [5] V. Rai, S. Sehwat, and K. Pandey, "Transient Stability Analysis of Wind Turbine Based Micro Grid using ETAP Software," vol. 3, no. 4, pp. 1515–1518, 2014.
- [6] S. Klungtong and C. Chompoo-Inwai, "Power flow monitoring and analysis for 24.6 MW at 6.9 kV bus Diesel Power Plant(DPP) using ETAP," *2016 Int. Conf. Smart Grid Clean Energy Technol. ICSGCE 2016*, pp. 307–312, 2017.

## AUTHOR(S) BIOGRAPHY



### **Fadhel Putra Winarta**

Fadhel Putra Winarta was born in Curup, January 24, 1993. Completed his undergraduate education at the Faculty of Electrical Engineering from 2011 to 2016. He obtained his S.Pd degree from Padang State University, Indonesia, in 2016, and is currently carrying out a master's degree at Andalas University, Indonesia.



### **Yoli Andi Rozzi**

Yoli Andi Rozzi was born in Bengkulu, January 15, 1987. Completed his undergraduate education at the Faculty of Electrical Engineering from 2005 to 2010. He obtained his ST degree from Bengkulu State University, Indonesia, in 2010, and is currently carrying out a master's degree at Andalas University, Indonesia.